



Interactive Swings: Assembly Guide

1. Components

1.1 Option based on Arduino Uno Wi-Fi Rev.2 (Wi-Fi)

Arduino Uno Wi-Fi Rev.2 board



GY-25A orientation sensor



1.2 Option based on Arduino Nano, Arduino Micro

Arduino Nano on CH340 chip, Arduino Micro

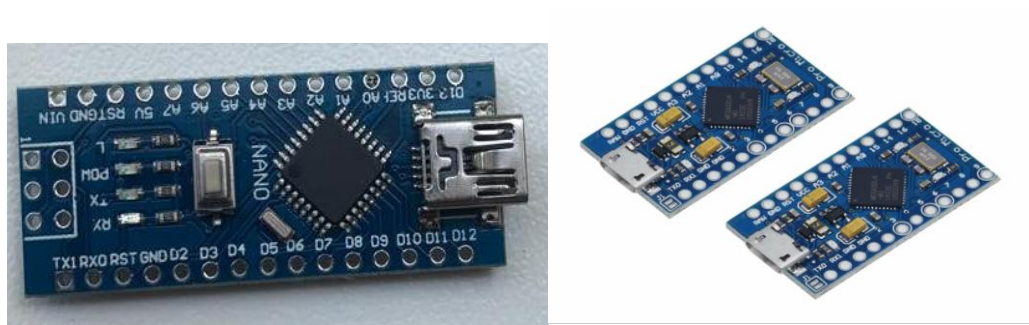

GY-25A orientation sensor



2. Wiring diagram

2.1 Option based on Arduino Uno Wi-Fi Rev.2 (Wi-Fi)

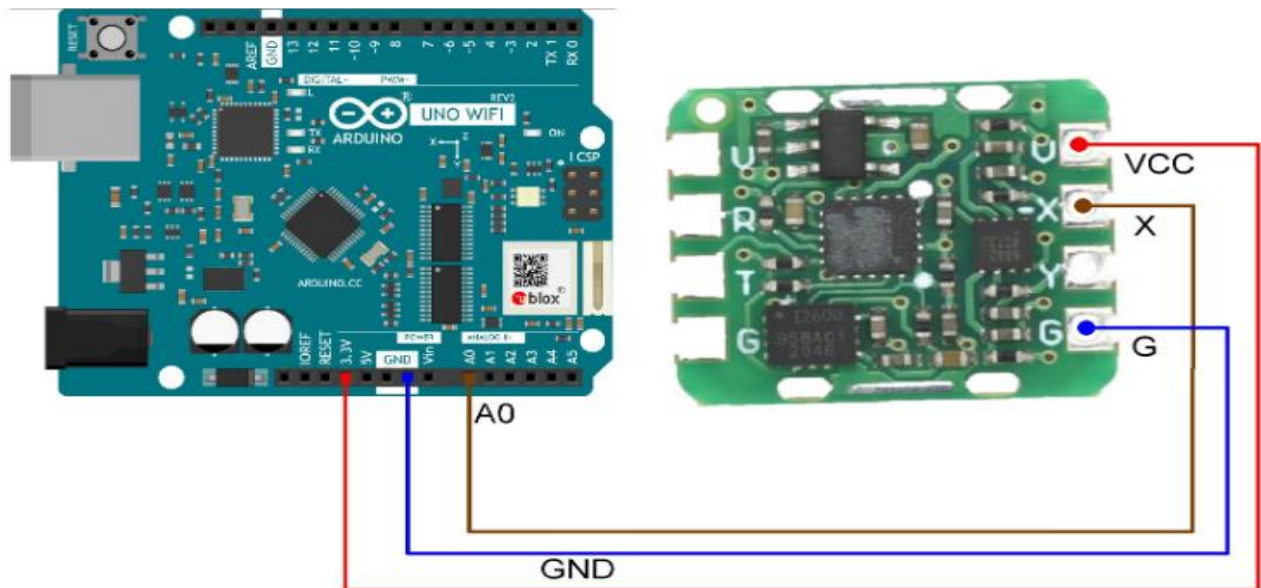

Fig. 1 Wiring diagram for Arduino Uno and GY-25A sensor

| Arduino Uno Wi-Fi Rev.2 | sensor GY-25A |
|-------------------------|---------------|
| 3.3V | VCC |
| A0 | X |
| GND | G |

Sensor VCC pin → connects to 3.3V on Arduino UNO Wi-Fi.

Sensor X pin → connects to A0 (analog input 0) on Arduino UNO Wi-Fi.

Sensor G pin → connects to GND on Arduino UNO Wi-Fi.

2.2 Option based on Arduino Nano, Arduino Micro

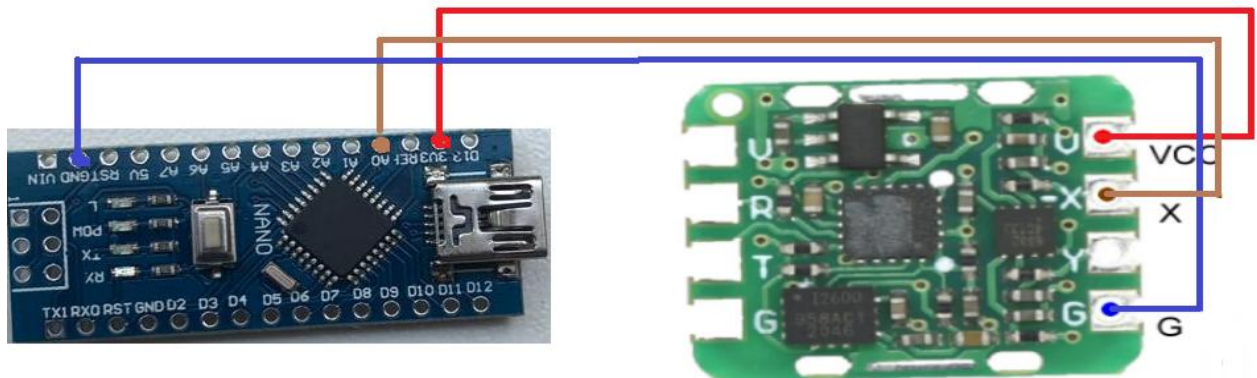

Fig. 2 Wiring diagram for Arduino Nano and GY-25A sensor

| Arduino Micro | Arduino Nano | Сенсор GY-25A |
|---------------|--------------|---------------|
| VCC | 3V3 | VCC |
| A0 | X | X |
| GND | G | G |

Sensor VCC pin → connects to VCC on Arduino Nano.

Sensor X pin → connects to A0 (analog input 0) on Arduino Nano.

Sensor G pin → connects to GND on Arduino Nano.

3. Assembly

3.1 Arduino Uno Wi-Fi Rev.2

Secure the Arduino board to the bottom of the enclosure using M1x5 or M2x5 screws.

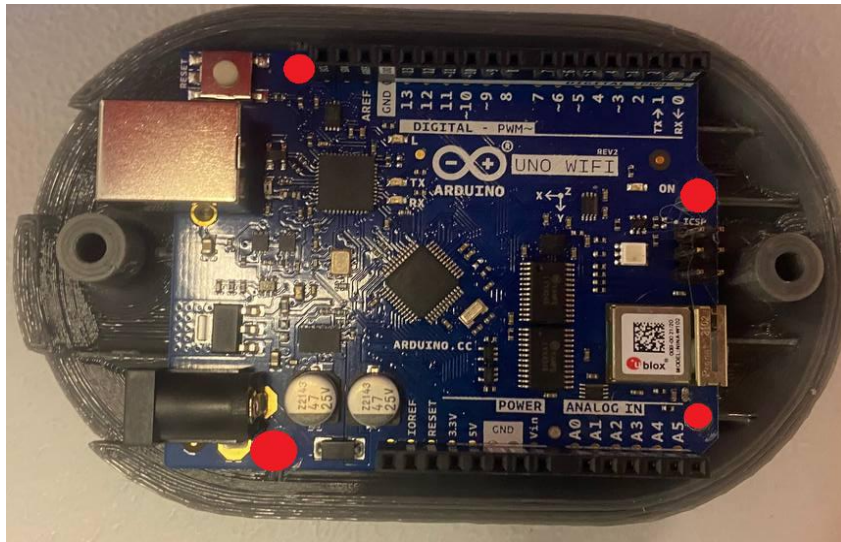

Fig. 3 Mounting points of the board on the enclosure

The position sensor is installed in the mount with the electronic components facing down.

The VCC, X, and G pins must face away from the Arduino pins (as shown in the figure). Then pull the Velcro strap through the holes.

Soldering wires to the pins is done on the component-free side.

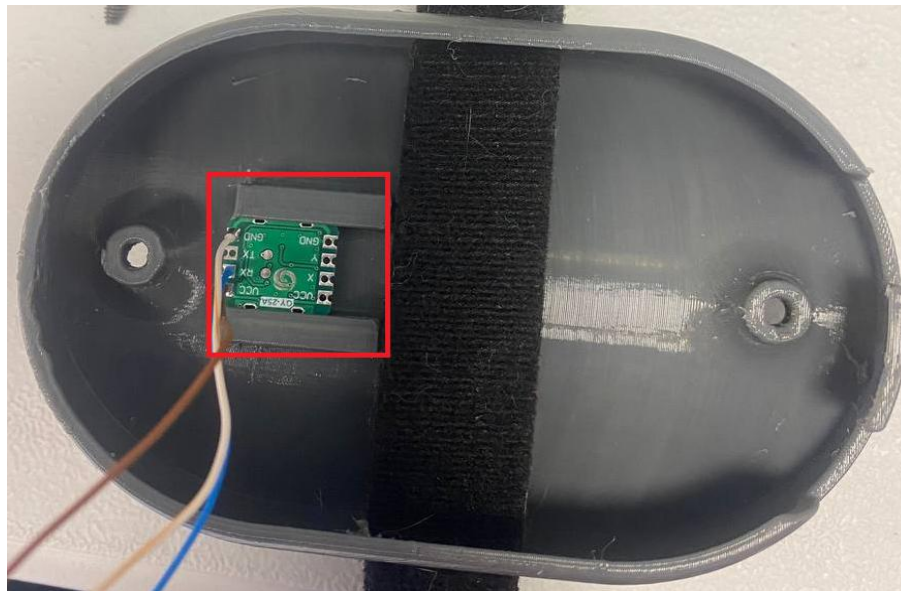

Fig. 4 Mounting the GY-25A sensor inside the enclosure

Connect the pins of the GY-25A sensor and the Arduino board according to **Section 2.1**.

Assemble the two parts together by screwing M3.5x20 self-tapping screws at the marked locations.



Fig. 5 Assembling the enclosure

3.2 Arduino Nano, Arduino Micro

Connect (solder) the pins of the GY-25A sensor and the Arduino board according to Section 2.2 Option based on Arduino Nano, Arduino Micro.

The sensor enclosure consists of 4 elements:

1. **The wire retainer** serves to prevent the wire from coming out of the Arduino's Type-C connector.



Fig. 6 Wire retainer

2. **The GY-25A board retainer** serves to secure the sensor inside the housing.



Fig. 7 GY-25A board retainer

3. **The top cover of the sensor** housing with double-sided tape applied for fixing to the swing frame.



Fig. 8 Top part of the sensor

4. The bottom part of the sensor housing contains the Arduino board and also holds the retainer for the board together with the GY-25A board.



Fig. 9 Bottom part of the sensor

Back side of the two housing parts



Fig. 10 Back side of the two sensor parts

After soldering the Arduino board and the sensor, install the sensor board into the retainer (see Fig. 7) so that the electronic components are facing upward, as shown in Fig. 11.

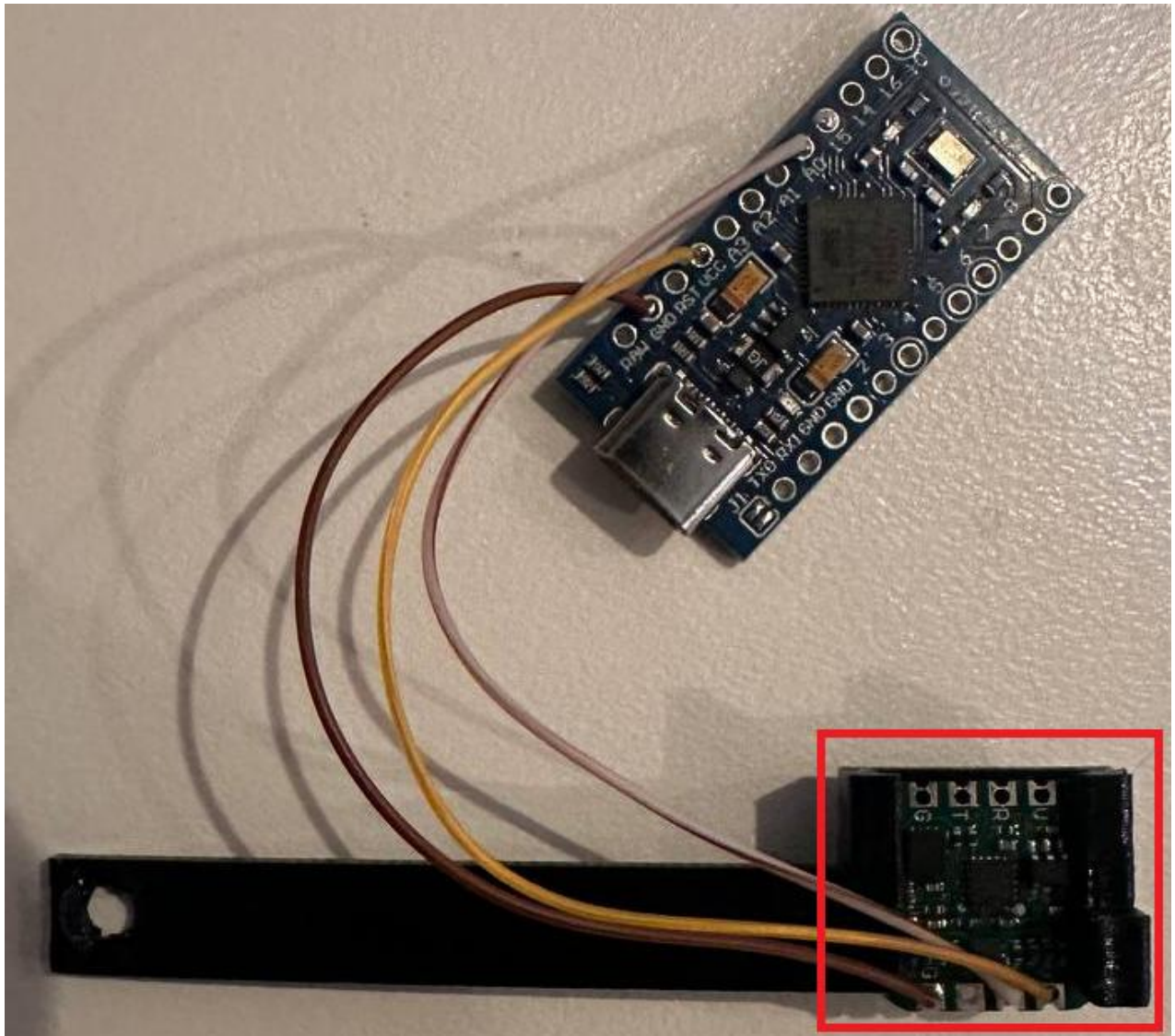

Fig. 11 GY-25A sensor inside the retainer

Connect the USB Type-C cable to the Arduino board. Then place the board inside the bottom part of the sensor housing (see Fig. 9), laying the Type-C cable into the designated groove. On top of the Arduino board, install the retainer with the sensor (see Fig. 11) and secure it with a screw. The result is shown in Fig. 12.

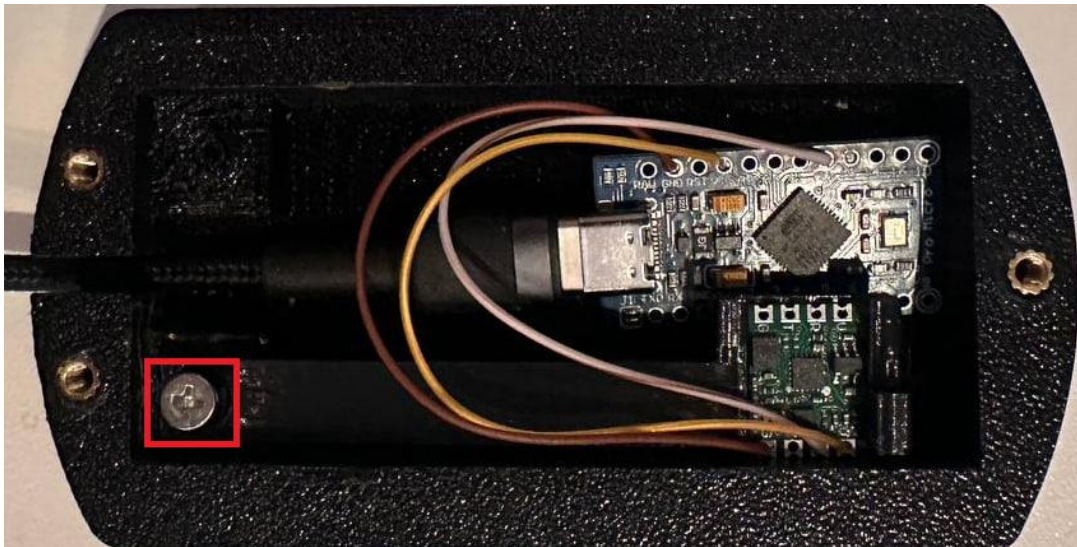

Fig. 12 Result of installing the Arduino board and the retainer with the GY-25A sensor

Install the wire retainer (see Fig. 6) into the groove with the wire, as shown in Fig. 13.

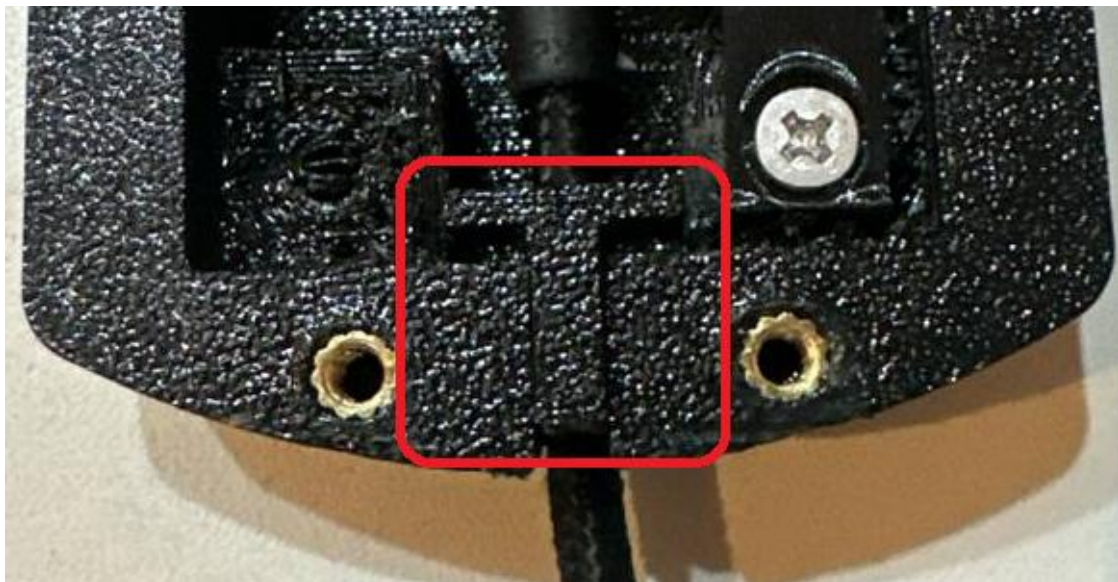

Fig. 13 Installing the wire retainer

Join the upper and lower parts of the sensor housing and secure them with screws (Fig. 14).



Fig. 14 Joining the two parts of the sensor with screws

Thread the Velcro strap through the special holes on the upper part of the sensor housing (Fig. 15).

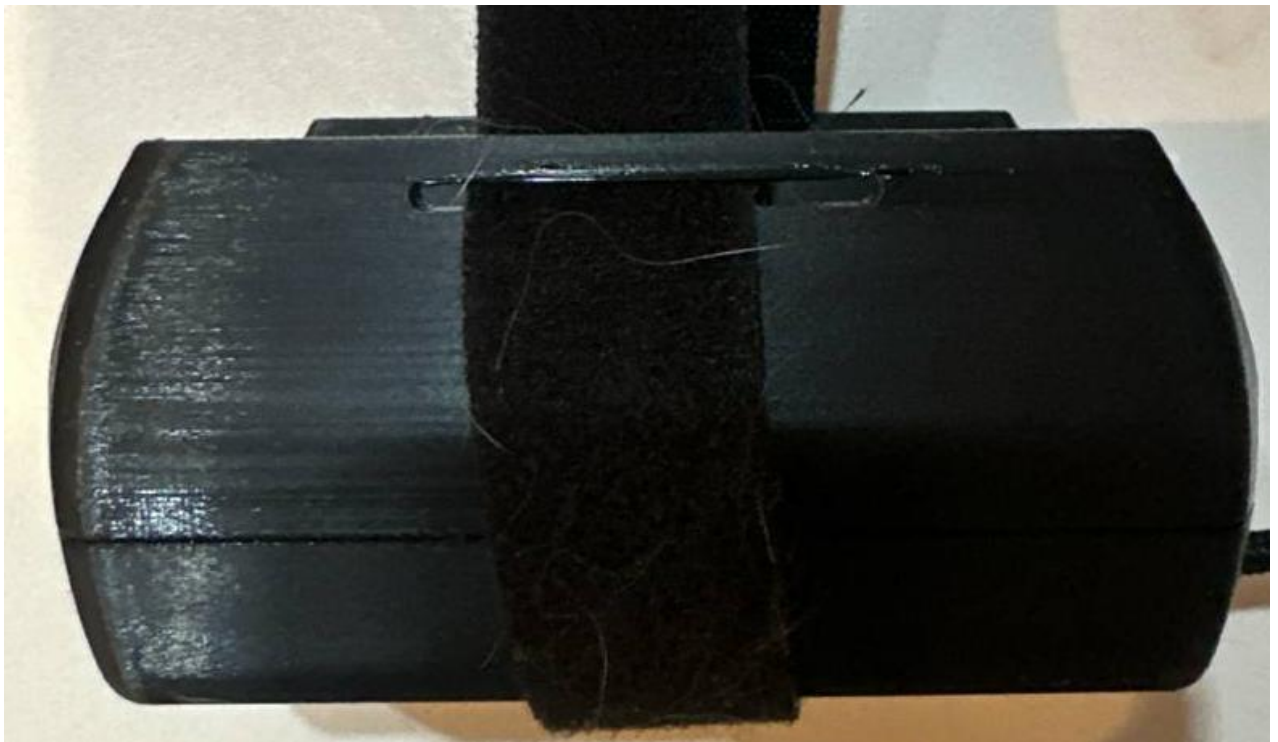

Fig. 15 Velcro strap for securing the sensor to the swing

4. Using the system

4.1 Installing Arduino IDE via USB interface

Download the Arduino IDE from the provided link and install it on your computer.

Connect the sensor to the computer using a USB cable.

Launch the Arduino IDE and make sure that the correct board is selected in the corresponding field: Arduino Uno WiFi Rev.2 as shown in Fig. 16, or one of the following: Arduino Nano or Arduino Micro.

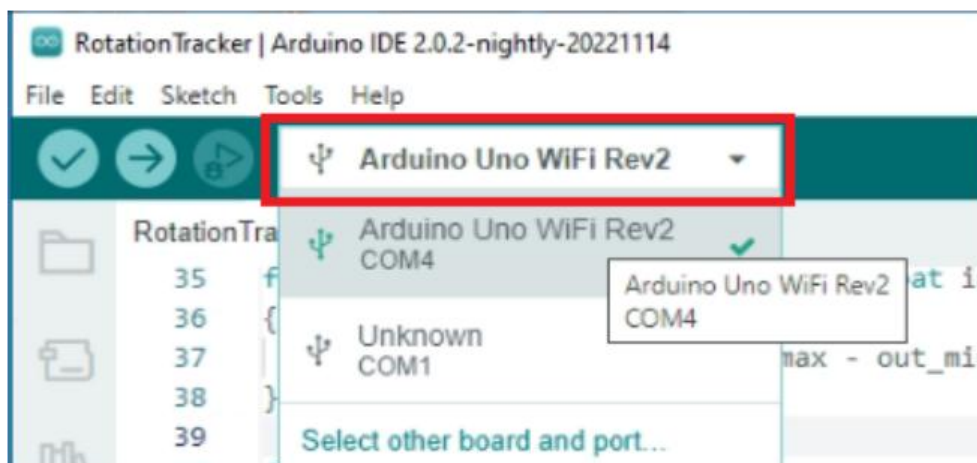



Fig. 16 Board selection field

In the left part of the menu, click the book-shaped icon  "Library Manager". In the search bar (highlighted in red in Fig. 17), type "WiFiNiNa", then click the "Install" button located below.

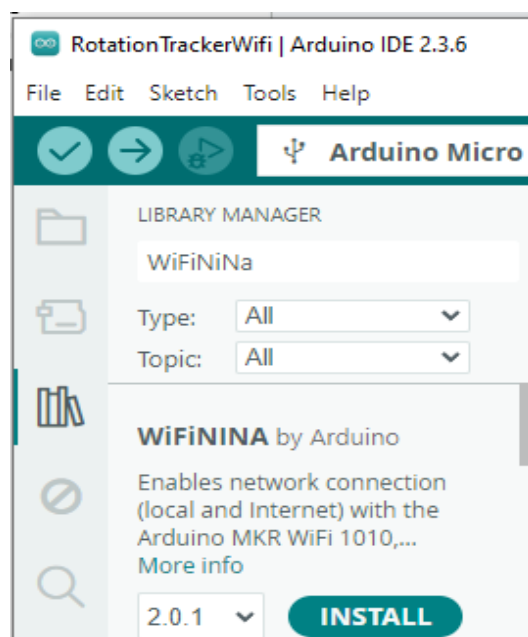

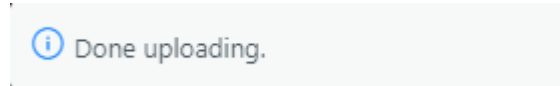

Fig. 17 Library search field

Download the sketch. Open the downloaded sketch file by selecting: "File" → "Open" → "RotationTracker.ino". If the IDE interface is in English, select: "File" → "Open" → "RotationTrackerUsb.ino". Then compile and upload the sketch to the board (sensor) by

clicking the arrow button . The sketch upload will begin. Upon successful upload, a corresponding notification will appear in the lower right corner of the program window.



Make sure the sensor is physically connected to the computer via a USB cable.

Open Device Manager using one of the following methods:

Right-click the Start button and select Device Manager;

Or press Win + R, type devmgmt.msc, and click OK.

In the Device Manager window, find the "Ports (COM & LPT)" section and expand it by clicking the "▶" icon next to the name.

The list will show an active COM device corresponding to the connected Arduino board. It will be named something like Arduino Uno WiFi Rev2 (COM1) or similar. The number after COM is the port number (in the example — COM1).

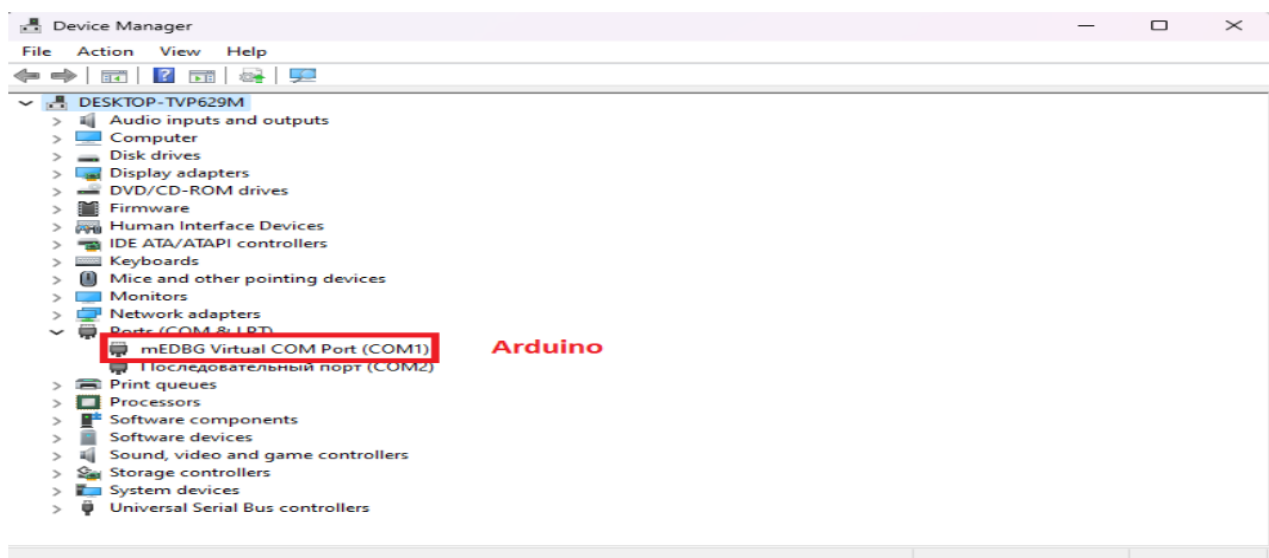

Fig. 18 Device Manager window

If the assigned port is not COM1, follow these steps:

In the Device Manager window, under the "Ports (COM & LPT)" section, locate the "mEDBG virtual COM Port" device (the name may vary), see Fig. 18.

Right-click on it and select "Properties" (Fig. 19).

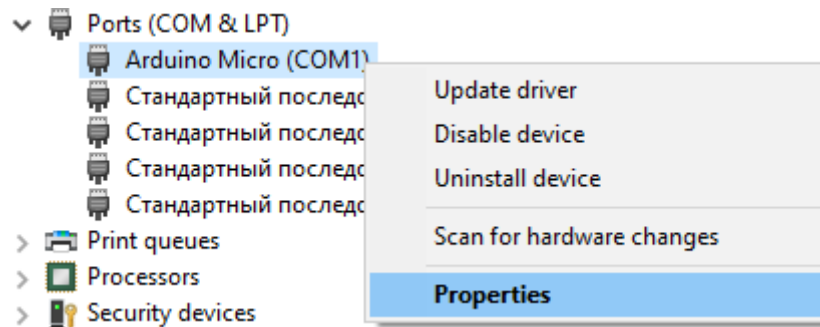

Fig. 19 Context menu when right-clicking

In the opened window, go to the "Port Settings" tab. Click the "Advanced" button (Fig. 20).

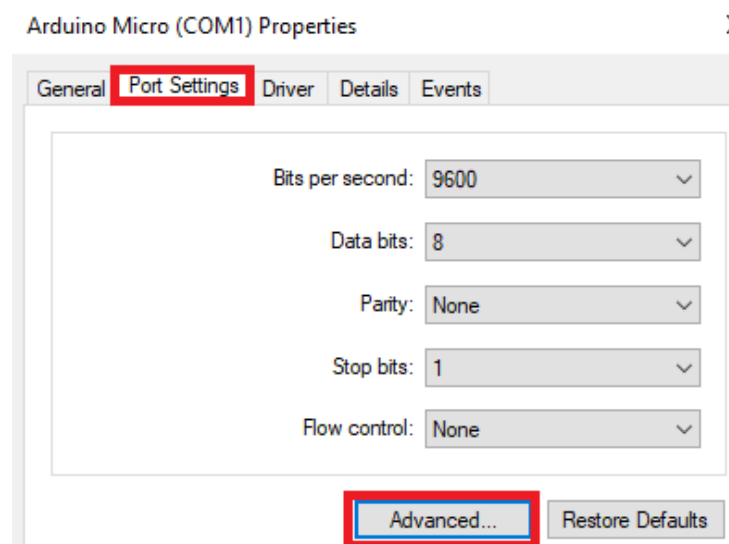

Fig. 20 Device properties

In the "COM Port Number" drop-down list (Fig. 21), select the value COM1. Click "OK" to save the changes in all open windows.

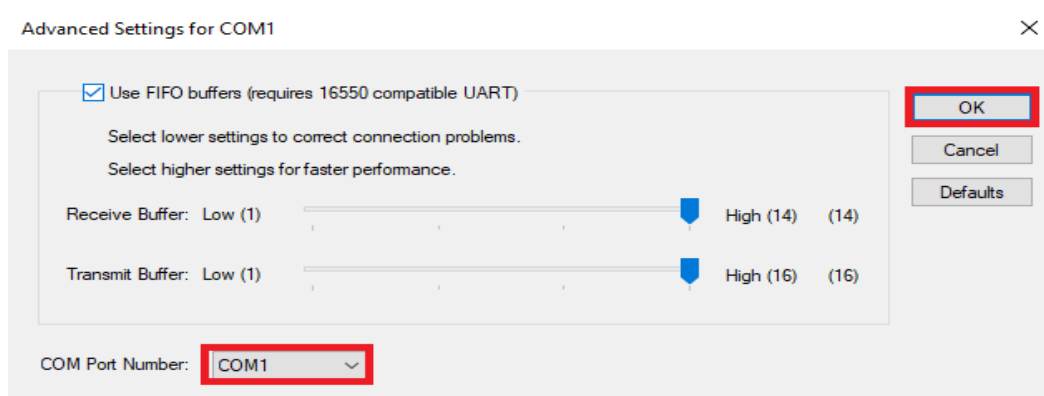

Fig. 21 Selecting the COM port

Restart your computer or reconnect the sensor.

4.2 Installing Arduino IDE via Wi-Fi interface

Installing the Arduino IDE is performed analogously to section 4.1.

If you have an Arduino Uno WiFi Rev2 board (or another Rev modification), you can configure the sensor to operate via Wi-Fi. **In this case, you must have a Wi-Fi router!**

To do this, download the RotationTrackerWifi sketch. Open the downloaded sketch file by selecting: "File" → "Open" → "RotationTrackerWifi.ino". If the IDE interface is in English, select: "File" → "Open" → "RotationTrackerWifi.ino".

Make the following changes in the sketch:

- char ssid — instead of "Your Wi-Fi network name", enter your network name
- char pass — instead of "Your Wi-Fi password", enter your Wi-Fi password
- IPAddress address — enter the IP address of the computer on the local network, for example 192, 168, 1, 1

Do not remove quotation marks, commas, semicolons, or brackets.

```
int status = WL_IDLE_STATUS;
char ssid[] = "          "; // your network SSID (name)
char pass[] = "          "; // your network password (use for WPA, or use as key for WEP)

unsigned int localPort = 2390; // local port to listen for UDP packets
unsigned int remotePort = 65500;

IPAddress address(192, 168, 1, 1); // time.nist.gov NTP server
```

Fig. 22 Example of editing the sketch

Then compile and upload the sketch to the board (sensor) by clicking the arrow button



. The sketch upload will begin. Upon successful upload, a corresponding notification will appear in the lower right corner of the program window.

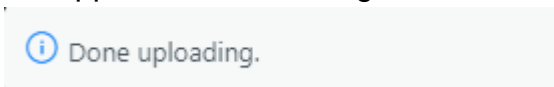

In this case, the number of the COM port to which the sensor is connected does not matter.

5. Sensor placement

The sensor is attached to the right side of the seat base using Velcro. The extension cable is attached to the swing hanger and then connected to the PC via a USB 3.0 port.

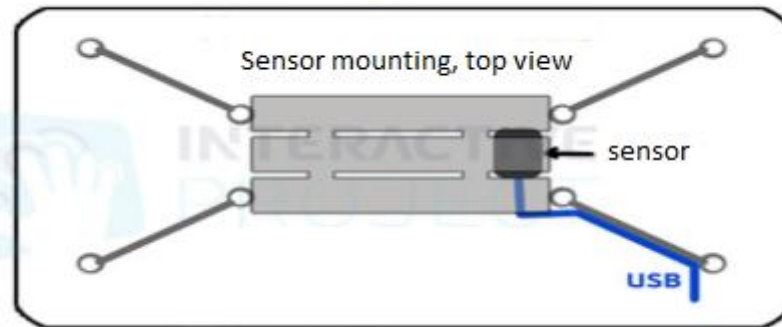

Fig. 23 Sensor mounting, top view

Front view



Side view



Rear view

